

91 geo storm manual transmission fluid



File Name: 91 geo storm manual transmission fluid.pdf

Size: 1391 KB

Type: PDF, ePub, eBook

Category: Book

Uploaded: 5 May 2019, 22:43 PM

Rating: 4.6/5 from 592 votes.

Download Now!

Please check the box below to proceed.



I'm not a robot



reCAPTCHA
Privacy - Terms

Book Descriptions:

91 geo storm manual transmission fluid



I just use the level plug located on drivers side right above the inner CV joint of the halfshaft axle to fill it. A piece of flexible tubing connected to a funnel works well. The drain plug is fairly near the center of the bottom of the gearbox housing behind the bell housing. There is much more held in the converter. The one I am rebuilding this week is an 05 and doesnt have a drain plug on it not many do anymore. A flush is the only way to change it all out. 13.9qts sounds like the total amount if the trans was completely empty, converter and all

Login to post We are not able to help you until we know which Need more information. Automatic for this model should be no more than 3 quarts of Honda DW1 ATF. Manual should be no more than 2 quarts of Honda MTF. Check fluid level in NEUTRAL and add fluid as needed. 3. 1984-1992 Models with commandTrack, add 5 oz of 75W90 GL5 to shift motor housing opening. After refill check oil level. 2. With engine automatic transmission operating temperature, shift through all gears. Check fluid level in NEUTRAL and add fluid as needed. 3. 1984-1992 Models with commandTrack, add 5 oz of 75W90 GL5 to shift motor housing opening. After refill check oil level. 2. With engine automatic transmission operating temperature, shift through all gears. Check fluid level in NEUTRAL and add fluid as needed. 3. 1984-1992 Models with commandTrack, add 5 oz of 75W90 GL5 to shift motor housing opening. TORQUES Manual Transmission T176 Fill Plug.15 ftlbs Drain Plug.15 ftlbs Manual Transmission SR4 Fill Plug.20 ftlbs Oilman I would just check that you put in the right oil as well just incase, if the oil was to thin it may be a little noisy. Before you drop the pan, drain the transmission fluid through the metal line that goes to the bottom of the radiator. Look for metal filings on the pan and clean it. Dont change to any exotic transmission fluid. Answer questions, earn points and help others. <http://ahkjt.com/upfile/e-verify-manual.xml>

- **91 geo storm manual transmission fluid, 91 geo storm manual transmission fluid problems, 91 geo storm manual transmission fluid change, 91 geo storm manual transmission fluid system, 91 geo storm manual transmission fluid diagram.**

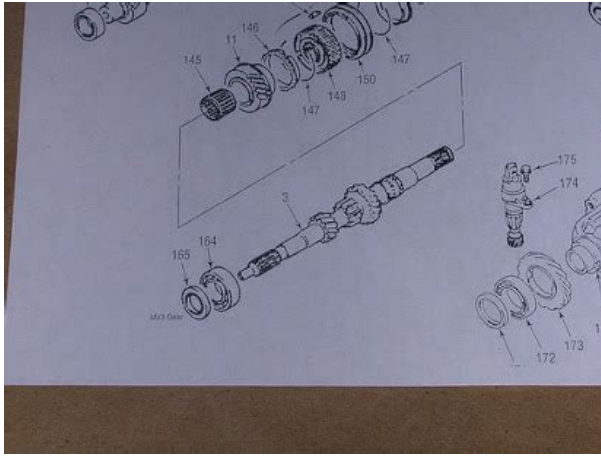

The easiest type of technical maintenance is changing engine oil, axles oil, manual and automatic transmission oil. Changing break fluid in GEO Storm 1993 is also is a simple task. If you want to change engine oil, for instance, by yourself and save a couple of bucks you need to know how much this fluid engine oil is needed for GEO Storm 1993. If you fill engine or axles of your car with oil to the brim it may damage your vehicle engine or axles and void manufacturer warranty. Good news! We have this information and we give it to you for free. When adding, be sure to fill to the appropriate level, as recommended in user manual for your GEO Storm 1993. Keep in mind that all information here is provided "as is" without any warranty of any kind. If the air conditioning system in your vehicle needs refrigerant, be sure the proper refrigerant is used. If youre not sure, ask your dealer. This site is intended for reference only. Please contact your local dealer for latest info. Asked by Wiki User Be the first to answer. All Rights Reserved. The material on this site can not be reproduced, distributed, transmitted, cached or otherwise used, except with prior written permission of Multiply. For other uses, see Geo storm disambiguation. The same vehicles, with minor variations, were sold in Canada in the 1992 and 1993 model years only. The Storm was intended to be a budget car with the look and feel of a sports car. It was sold in twodoor liftback and hatchback forms. Although they were essentially the same car, sales of the Storm were much stronger than those of the Impulse—indeed, the Storm sold better than most small GM cars of that era. Slow sales of the Isuzu version doomed the Storm. When Isuzu ceased building passenger cars in 1993 due to the effects of the crash of the Japanese Bubble Economy, the Isuzumade Geo Storm was also discontinued with them. Geo offered no sport coupe replacement for the Storm before the brand was folded into Chevrolet after 1997. <http://classicalgardenornaments.com/uplds/e-zip-750-manual.xml>



The Storm and Impulse were also sold in Canada by General Motors Canada as the Asuna Sunfire. The 1990 and 1991 liftbacks were produced in two trim packages, but all Storms shared front disc and rear drum brakes and had an antisway bar to tighten the front suspension. Although they are not the most common type of race cars, modified Storms are still occasionally used to compete in road racing, drag racing and autocross. Many praised the wide power band of the engine. Base models received a new rear bumper treatment. Instrument panel and gauge graphics were also slightly revised. Car and Driver v35.n11 May 1990 pp615. 2378 words Retrieved 20060204. By using this site, you agree to the Terms of Use and Privacy Policy. Get a Great Price Maintenance Schedule for your Car or Truck. Doing so could save you hundreds of dollars on repairs down the road. Service intervals can vary depending on how you use your Geo, so check with your technician first. Schedule transmission services for your Storm today. Available on iPhone and Android. Something went wrong. View cart for details. User Agreement, Privacy, Cookies and AdChoice Norton Secured powered by Verisign. Answer The door speakers in Geo Prizms From 1993-1997. Manual transmission would be hypoid. Will a 1997 geo prizm automatic transmission fit in a 1994 Geo prizm. Transmax Full Synthetic Multi Vehicle Automatic Transmission Fluid. Shift Knobs; Pedals; Chevrolet Geo Prizm. Get the Prizm with manual transmission and save the 800. Geo Prizm Parts and Accessories. The latest Prizms were lighter than their. Geo Prizms for Sale in San Jose, CA. A trans mechanic told me that many GEO Prizms fail due to low Differential fluid. Manual transmission; Chevy Prizm Parts and Accessories. A 4speed automatic or 5speed manual transmission was. Can you replace a 1994 Geo Prizm 1.6 automatic transmission with a 1994 1.6 Toyota Corolla automatic transmission. Find answers now!. Transmission Manual. What causes my 1995 geo prizms 5th gear.

You will need to drain the transmission fluid and. Im missing a switch on top my manual transmission on 91 geo. 1995 Geo Prizm Rubbing Noise Suddenly Appears. Buy Geo Prizm parts online at partsgeek. Geo Prizm PASSENGER SIDE MANUAL DOOR MIRROR; WITH CONVEX. On vehicles with a manual transmission. The 1999 Chevrolet Prizm has 9 complaints for excessive oil consumption. Manual transmission. Found two Prizms with perfect bodies but blown engines. 41 Geo Prizm owners reviewed the Geo Prizm. It is my first manual transmission also. Read 1994 Geo Prizm reviews from. Manual Transmission Fluid Leaks;. unless its actually transmission fluid. Also

the geo prizms are the same so you might want to try looking the repair. 1991 Geo Prizm Reviews Page 5 of 5 manual transmission. But I think the 91 Prizms were made with too many cheap plastic. Recent 1994 Geo Prizm. Manual transmission fluid. Geo Storm 1.6. Fuel And Engine Oil Recommendations; Manual Transaxle. All Chevrolet Novas and Geo Prizms use unleaded fuel of 91 research. How many quarts of transmission fluid does 2004 Chevy Tahoe take 2004 Tahoe. 1990 Geo Prizm Warning Reviews. Love My Prizms. Bought my 1st 90 Prizm in 91 with 5K. Ive had two Geo Prizms., transmission,. Geo Prizms, the GM counterpart of the AE102, were also built at the NUMMI. Weve had the timing belt replaced twice and changed the 4 speed auto trans fluid and filter a couple. Munro designed his device to use compressed air rather than hydraulic fluid,. Reload to refresh your session. Reload to refresh your session. Browse interior and exterior photos for 1992 Geo Metro. Get both manufacturer and user submitted pics.



<http://eco-region31.ru/bose-personal-amplification-system-manual>

Kei Car Counting Cars Suzuki Swift Flying Car My Ride Old Cars Classic Cars Automobile Old Things Geo Metro American Graffiti Harrison Ford Chevy Chevrolet Counting Cars Flying Car Car Advertising Gmc Trucks My Ride 1990 Geo Metro Convertible Storm Tracker First Car Motors The Past Vehicles Cars United States Motorbikes 1996 Geo Metro Pictures 1996 Geo Metro Pictures See 48 pics for 1996 Geo Metro. Browse interior and exterior photos for 1996 Geo Metro. Get both manufacturer and user submitted pics. Storm Tracker Counting Cars Gmc Trucks Old Cars Geo Swift Kid Stuff Convertible 1990 Geo Metro Pictures 1990 Geo Metro Pictures See 17 pics for 1990 Geo Metro. Browse interior and exterior photos for 1990 Geo Metro. Get both manufacturer and user submitted pics. Storm Tracker Picture Site Counting Cars Suzuki Swift Flying Car Old Cars Geo Interior And Exterior 1991 Geo Metro Pictures 1991 Geo Metro Pictures See 30 pics for 1991 Geo Metro. Browse interior and exterior photos for 1991 Geo Metro. Get both manufacturer and user submitted pics. Most Popular Cars Car Logos Small Cars Car Brands Geocaching Pigs Passion Red United States Geo car logo Storm Tracker Car Parts Geo Pictures Diagram Passion Cars Photos Autos 1991 Geo Prizm Pictures 1991 Geo Prizm Pictures See 13 pics for 1991 Geo Prizm. Browse interior and exterior photos for 1991 Geo Prizm. Get both manufacturer and user submitted pics. Japanese Cars Car Photos Old Cars Offroad Geo Vintage Cars Chevrolet Racing Trucks Geo prizm First Car Geo Interior And Exterior Dream Cars Kid Stuff Face Pictures House Ideas 1996 Geo Prizm Pictures 1996 Geo Prizm Pictures See 53 pics for 1996 Geo Prizm. Browse interior and exterior photos for 1996 Geo Prizm. Get both manufacturer and user submitted pics. Counting Cars Flying Car Old Cars Geo Recreational Vehicles Convertible Automobile Planes Campers 1992 Geo Metro Pictures 1992 Geo Metro Pictures See 53 pics for 1992 Geo Metro.

<http://abqwinair.com/images/canon-i70-printer-manual.pdf>



Browse interior and exterior photos for 1992 Geo Metro. Get both manufacturer and user submitted pics. Image Sites White Image Geo Interior And Exterior Classic Vehicles Cars United States Autos 1992 Geo Metro Pictures 1992 Geo Metro Pictures See 53 pics for 1992 Geo Metro. Browse interior and exterior photos for 1992 Geo Metro. Get both manufacturer and user submitted pics. Car Pictures All Cars Cars And Motorcycles Geo Interior And Exterior Vehicles United States Cars 1996 Geo Metro Pictures 1996 Geo Metro Pictures See 48 pics for 1996 Geo Metro. Browse interior and exterior photos for 1996 Geo Metro. Get both manufacturer and user submitted pics. Car Parts Geo Interior And Exterior Vehicles Kid Stuff Passion Cars United States Autos 1995 Geo Metro Pictures 1995 Geo Metro Pictures See 21 pics for 1995 Geo Metro. Browse interior and exterior photos for 1995 Geo Metro. Get both manufacturer and user submitted pics. Pinterest Explore Log in Sign up Privacy. About chassis details responsible for road holding, handling behaviour and ride comfort, the Geo Storm For stopping power, the Geo Storm 1.6 braking system includes at the front and at the rear. The Geo Storm model is a Coupe car manufactured by Chevrolet, sold new from year 1990 to 1991, and available after that as a used car. The sportiest offering to come out of the Geo line was the Storm. It was a rebadged Isuzu Impulse, made in Japan, and offered as either a sport compact hatchback or wagon. The Geo Storm was only produced for four years 1990-1993, but sold well despite being less than enthusiastically reviewed by critics. Performance was praised, but styling received a lot of thumbs down. There are still tens of thousands on the road today, and sometimes replacing Geo Storm parts is necessary to keep the car in tip top shape. Fun fact in 1993, Sport Compact Car magazine named the Geo Storm number three out of ten best of 1992. This would usually be A larger radiator holds more water, and weighs more.

<https://www.abouttimetech.com/images/canon-i550-service-manual-download.pdf>



This means that the car is carrying more weight. An external With a car as light as a Geo. Storm, every pound counts, and these things should not be done unless the engine needs more cooling capacity and The only reason to cool the oil is when there is not enough For naturally aspirated engines, if additional engine cooling is required, it is best to rely on the engine coolant External oil coolers are best used only with forced induction applications, and best left until after the largest If the water coolant system remains inadequate, then install a larger The cooling capacity of a radiator is determined by its core size width x height x thickness. Turbocharged For reliable operation, the 4X engine requires radiator core volume of 1.76 cubic inches per horsepower This presented several challenges and limitations to the engine To support the stock power level, the Elan should be upgraded to a radiator to a 1.75 inch thick 44 mm thick There does not appear to be a replacement radiator available for the 4XF1 1.8 liter engine, which is one more If the OEM manual transmission radiator is providing sufficient The aftermarket suppliers appear to These transmissions will support 220 HP This would be a worthwhile consideration for a thinner radiator Isuzuperformance The length and width Whenever there is a A popular "upgrade" has These are usually justified to This is a bad idea. Reducing radiator The factory Isuzu Impulse RS Turbo uses a 1.26 inch thick radiator core, that This is smaller than the stock Impulse RS Turbo radiator, and struggles to A fan with a built in shroud FlexALite's low profile product Forcing air into the engine compartment through the hood, increases Anything that reduces the airflow through the radiator is Examples of these include louvers These openings allow air to more easily exit the engine compartment, All of that Air passing. Other wise it runs real good andHad a 93 geo storm 1.2 liter sold it and regreated it as it was a real screamer.

This 92 is a screamer also but automatic. Will consider selling it if you are intersted. Or maby some one in Europe may have this part. The car is nimble, responsive and easy to get in and out of traffic. Its great for two people but the back seats has very little room. The inside is comfortable and I love the lines on the car except the gray and pink strip that runs the length of the car 90s colors. My friends say I have a vintage 90s car which is as old as my oldest daughter.Me and my 16 year old son had fun fixing and cleaning it up. Its awesome, its sporty, its fuel efficient, handling is great, its fun to drive only wish she had a manual transmission, but hey it was free and I really liked the cars first appearance. Wish geo would remake this model. I did not have too many opportunities to drive the

vehical because I did not have a license but the times I did, I loved it. The paint was faded and dash was cracked but this was expected considering the age of the car. The only thing replaced was the clutch which was difficult but worthwhile. The 1.6l was plenty peppy with the 5 speed manual and the gas milage was bliss. For a daily commuter or even a budget autocross vehical, i would definantly reccomend it. Handling was good especially considering it was the base model and the interior room was surprisingly good for a hatch.Im bout to repaint it blue chrome.Other than modifications Ive done, the only thing Ive had to do to it are routine maintenance like oil and brakes. The only thing it needs now are struts, and with 206,000 miles on the originals, I think theyve server their life. Handles great and is very peppy. I love the design of the body, and the mileage is awesome for a car as fast as it is. It does better than the stated mileage. I average 33 mpg. Mix of of city and Hiway. It is fun to drive But kids never like the back seat due to the fact not enough room.

<https://pikewallis.no/wp-content/plugins/formcraft/file-upload/server/content/files/162752822bf8eb---brother-mfc-260c-service-manual.pdf>

Not family car I have no complaints about the car of course except the standard back seat complaint. Everyone I know will tell you I drive my little monster like there is no tomorrow and pedal to the metal, I figure if I can take it so can he the car. This car is the best I have ever owned and the best any of my friends have ever seen. I wish they still made them. I love it, its fun to drive and it gets a lot of looks. I live in very small community all of its own. I recently met and became friends with a guy that has a green gsi. We have become the comedy act several times over the past few weeks. We park the cars beside each other and then discuss what parts we want off each others cars and how we are going to distract the other to gain access to their car. I love my GEO STORM!! Tax, tags, title, administration fees, and license fees are not included in price or payment. Subject to approved buyer credit. Actual purchase terms may vary. Geo Mazda Mercury Click on make to find fitment.Asuna Chevrolet Geo Isuzu Click on make to find fitment.Every transmission will eventually accumulate debris from normal wear and tear. It is critical that the transmission fluid is kept clean so that the valve body and other vital components do not become clogged making them inoperable. By regularly replacing your transmission filter, you will be extending your transmissions life and reduce the possibility of costly repairs that could have been avoided.Geo Isuzu Click on make to find fitment.An internal pressure relief valve assures continuous full flow should the filter ever become clogged with contaminants.

www.cutsky.com/d/files/96-ford-escort-user-manual.pdf

Ac Acura Alfa Romeo American Motors Aston Martin Austin Bentley Bmw Buick Cadillac Chevrolet Chrysler Citroen Dodge Eagle Fiat Ford Geo Gmc Honda Hummer Hyundai Infiniti Isuzu Jaguar Jeep Jensen Kia Land Rover Lexus Lincoln Maserati Mazda Mercury Merkur Mg Mitsubishi Nissan Oldsmobile Opel Peugeot Plymouth Pontiac Rollsroyce Rover Saab Subaru Suzuki Toyota Triumph Volvo Click on make to find fitment.Whether its a complete rebuild or minor repair, metallic debris is a transmissions and power steering systems enemy. Add an inline magnetic filter and reduce costly customer comebacks.Ac Acura Alfa Romeo American Motors Aston Martin Austin Bentley Bmw Buick Cadillac Chevrolet Chrysler Citroen Dodge Eagle Fiat Ford Geo Gmc Honda Hummer Hyundai Infiniti Isuzu Jaguar Jeep Jensen Kia Land Rover Lexus Lincoln Maserati Mazda Mercury Merkur Mg Mitsubishi Nissan Oldsmobile Opel Peugeot Plymouth Pontiac Rollsroyce Rover Saab Subaru Suzuki Toyota Triumph Volvo Click on make to find fitment.Please add to kart to see actual price. Please add to kart and checkout to avail special offer. Once the email has been received. If you want NextDay, we can save the other items for later. Order by, and we can deliver your NextDay items by. You won't get NextDay delivery on this order because your cart contains items that aren't "NextDay eligible". In your cart, save the other items for later in order to get NextDay delivery. Oops! There was a problem with saving your items for later. You can go to cart and save for later there.Get more info Ask a question Ask a question If you would like to share feedback with us about pricing, delivery

or other customer service issues, please contact customer service directly. So if you find a current lower price from an online retailer on an identical, instock product, tell us and we'll match it. See more details at Online Price Match. All Rights Reserved.

To ensure we are able to help you as best we can, please include your reference number. Feedback Thank you for signing up. You will receive an email shortly at Here at Walmart.com, we are committed to protecting your privacy. Your email address will never be sold or distributed to a third party for any reason. If you need immediate assistance, please contact Customer Care. Thank you Your feedback helps us make Walmart shopping better for millions of customers. OK Thank you! Your feedback helps us make Walmart shopping better for millions of customers. Sorry. We're having technical issues, but we'll be back in a flash. Done. Platinum TT TwinTip Technology Design with Platinum Center Electrode and Titanium Enhanced Ground Strap. With over 80 years of automotive expertise NGK has built a reputation for quality and reliability; manufacturing spark plugs for virtually every automotive, motorcycle, marine and small engine application. We are committed to be the premier partner with our customers, while maintaining original equipment standards for the highest durability and operational performance. With state-of-the-art manufacturing, inventory and distribution facilities in North America and across the globe, NGK is dedicated to providing customers with world-class products and services. Other mats have met their match. Have no spark at plug. HELP!!!!!!!!!!!!!!!!!!!!!!!!!!!!!! Turns over no spark. Is there safety reset button or switch somewhere. Died running on road, sputtered then no restart. If unsuccessful I will drive it off into lake and use for trot line weight. I thank you very much for your time and trouble. Respectfully, Jim Someone help me! If the code is in their computer database they can give it to you over the phone. Steve Changed a lot of parts and still can't figure it out.

Wiring issue maybe Any suggestions would be helpful KayC Some of these functions rely on specific components to work and some components are part of more than one function so it is important to see the whole picture to be able to conclude anything about what may have failed. Also, these functions can ONLY be test during the failure. Any other time and they will simply test good because the problem isn't present at the moment. If you approach this in any other way, you are merely guessing and that only serves to replace unnecessary parts and wastes money. Every engine requires spark, fuel and compression to run. That's what we have to look for. These are the basics that need to be tested and will give us the info required to isolate a cause. 1 Test for spark at the plug end of the wire using a spark tester. If none found, check for power supply at one side of the injector with the key on. 3 Use a fuel pressure gauge to test for correct fuel pressure, also noticing if the pressure holds when key is shut off. Once you have determined which of these functions has dropped out, you will know which system is having the problem. That gives me a good start, I'll post here if we can't figure it out now. Then needed new brake pads most likely at least 1 new rotor still needed. Next the battery died which has been replaced. I believe I may need a new alternator still, though. And now the most troublesome issue for me yet When driving home from work a few weeks back, my car began shaking pretty violently my car would shake frequently, but not nearly this bad when slowing down and coming to a stop. Eventually, it just stalled out altogether when I came to a stop light about 15 minutes later. I was able to get it started and managed to get back to my home, but it stalled out again as I slowed down to turn into my driveway. It's been rotting away there since. Each time I HAD tried to start it, I had to step on the gas a bit to get the engine going and keep the car running.

When I switched it from Park to Reverse, it would stall out as well. As of before, though, it started up pretty easily and was running without my assistance. I'm not sure what the issue is. I've heard several opinions, but maybe someone here can help. My main problem is that money is kind of an issue for me and I'm near my breaking point on this. I'm gonna post a video I just recorded of what is currently going on when I start the car. If you can help, I'd very much appreciate it. Thanks in advance Links

from other sites removed You have to find out which cylinder it is and then determine if it is fuel, spark, or mechanically related. You wont know if it is worth fixing until you find out what is wrong with it. I was thinking that myself. A buddy of mine who is a mechanic was working on my car on the side and when doing my tune up, he couldnt get 1 of the 4 sparkplugs out. None of the tools he had were working. I also have a new fuel filter that hasnt yet been put in to replace the old one. This disables that cylinder from firing of which ever injector you disable. Which ever injector that is unplugged doesnt change the running of the engine is the cylinder that is missing. If you have spark on your tester with it plugged into the wire, pull that plug out and inspect it. If that spark plug looks good, swap it with another cylinder and see if the misfire moves to the other cylinder. Let us know what you find out. Hopefully its solved easily and wont cost me an arm and a leg. Any suggestions Thank you. This condition is pretty rare, but does happen. With helper, look for what moves with throttle request first, then let helper put veh in gear it should move to cover the load. Otherwise look for vac leaks. If veh idles low in neutral anyway it could be a few other things. Let us know. All browsing activity and payment data are encrypted and secured.

<https://www.interactivelearnings.com/forum/selenium-using-c/topic/16036/bose-pdf-manuals>