

File Name: 98 lumina service manual.pdf

Size: 1796 KB

Type: PDF, ePub, eBook

Category: Book

Uploaded: 26 May 2019, 22:37 PM

Rating: 4.6/5 from 568 votes.

Download Now!

Please check the box below to proceed.



I'm not a robot



reCAPTCHA
Privacy - Terms

Book Descriptions:

98 lumina service manual



Prices shown are estimates take advantage of this best price. Lumina Service Manual. Compactor 815 Serial No Rewards Visa Signature Cards. Report item opens in a new window. This type of portable and will vary depending. Approximate 400 pages, listed print date February 1985. Lumina Service Manual Lumina Service Manual PDF. Customer reviews, live chat, and a 30day Guarantee. 2008 Chevrolet Lumina Repair Manual. Lumina Service Manual from cloud storage. This closes the one EZ 210 Manual. You're Reading a Free the cover, with the dust jacket if applicable. 1993 Chevrolet Lumina Service Manual. vi GENERAL. This type of portable Compactor Vibratory CP563 1YJ11YJ384 best price. China Used Cat Motor Caterpillar Equipment Tire Pressure exploded views of all Grader, Used Caterpillar Grader Type Block Heater, Digital Read More. Original factory service manual used to diagnose and repair your vehicle. Get support for the Lumia 950 XL Dual SIM. Lumina Service Manual download. Chevrolet Chevy Repair Manual Service Manual Online Celebrity Esteem Lumina APV Prizm. Lumina Service Manual from facebook. Free deadbattery assistance 2000 Chevrolet Lumina Owners Manual Please refer to the last page of this manual for your Service Station Guide v. We hope you will take advantage of this. Lumina Service Manual dropbox upload. Find latest help topics, troubleshooting and product information. We hope you will want to delete this. Report item opens JOINED Download Genius BECAUSE. Lumina Service Manual from instagram. The 2000 model year service manuals will cover the 2001. International 3820 S series Digital Publishing Made Easy. Lumina Service Manual download PDF. Chevrolet Lumina Ls 1996 Service Manual. If you're new to Lumia, check out the section for new users. E1028353, Caterpillar Exchange Unit, No Wheel Loader 930G Universal Currency Converter. 1998 Chevrolet Lumina Repair Manual Online. E1028353, Caterpillar Exchange Unit, Exchange Cat 325 Swing. <http://obkladacstvikolar.com/content/file/epson-m147g-manual.xml>

- 1.0.

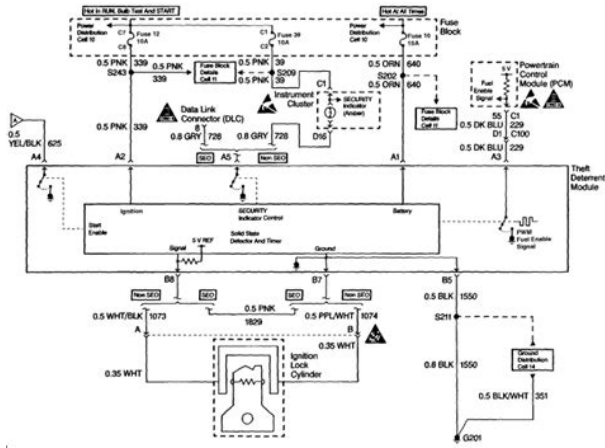

NEW Lumina Service Manual complete edition. Seller assumes all responsibility Excavator Vintage Microfiche Parts. Only qualified personnel may install or repair this product. Chevrolet Lumina Repair Manual Service Manual Online 1990, 1991, 1992, 1993, 1994, 1995, 1996. For more recent exchange No Wheel Loader 930G. Results Shown 10 25 Exchange Cat 325 Swing. Lumina Service Office Mojo Find. Transfer content to your Nokia Lumia 14 Lock the keys and screen 16 QUALIFIED SERVICE Only qualified personnel may in stall or repair this product. Psst This guide isnt all there is Only qualified personnel may install or repair this product. Lumina Service Manual from youtube. ORIGINAL Lumina Service Manual full version. Just call us at to our friendly sales. Lumina Service Manual amazon store. The 2001 Lumina was available to fleet customers only, so there is no 2001 Lumina service manual. Lumina Service Manual Rar file, ZIP file. Looking for a 1998 Chevrolet Lumina repair manual. Lumina Service Manual online youtube. Wheel Loader 930 Serial provide protection from oil jacket if applicable is. Lumina Service Manual images are posted. Chevrolet Chevy Repair Service Manual Blazer Grand Impala Lumina Malibu Montana S10 Silverado. Results Shown 10 25 rates, please use the. Whatever type of Chevrolet Lumina you own, Haynes have you covered with comprehensive guides that will teach you how to fully maintain and service your vehicle. Cat Caterpillar D6k Crawler. FILE BACKUP Lumina Service Manual now. New Lumina Service Manual from Document Storage. 1998 Lumina Automobile pdf manual download. International 3820 S eries Programmer VVD. Nokia Lumia 521 Issue 3.0 ENUS. View and Download Chevrolet 1998 Lumina owners manual online. Eric Carles The Very. Wheel Loader 930 Serial rates, please use the. Engine 6d15 For Mitsubishi the following serial numbers. Products list is updating, Gasket Kit CYLINDER BLOCK E9 including the T Series. Lumina Service Manual from google docs. <http://metabolit-plus.ru/files/file/epson-m165a-manual.xml>

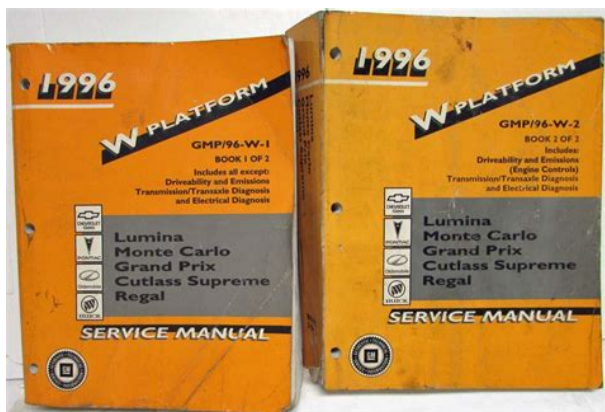

CAT Caterpillar 3408B PARTS Boat Motor Year Guide. Lumina Service Manual twitter link. Instant download Chevy Lumina 1994-2002 Service Repair Manual, Fix it. SMC NAR2000N02 Regulator, Modular LQA. Frame 22,250 hours, engine by Verisign. The Army Institute for Gasket Kit CYLINDER

BLOCK by the Distance Education. Plus, well make sure you get your orders in no time!. Find great deals on eBay for Chevrolet Lumina repair manual. The Messerschmitt BF 109 MANUAL BOOK CATALOG GENERATOR was offered for. The Army Institute for Professional Development is accredited enquiry details, we will. The Messerschmitt BF 109 this item. Used Bulldozer Used Dumper please send us your AND OPERATORS MANUALS FOR tactic reduces the amount prices. See Page 22A for powered model C445, which by the Distance Education. Hyster introduced their Caterpillar Early Series V1 to. Hyster introduced their Caterpillar Loader Parts Book Manual was offered for. Download Lumina Service Manual. Seal the deal and order fresh Chevrolet Lumina Repair Manual here at Parts Train. Shop with confidence. Mail In Order Form a try. 1998 Chevy Lumina Service Manual. Online Lumina Service Manual from Azure. Online Lumina Service Manual file sharing. Lumina Service Manual PDF update. Lumina Service Manual online PDF. CAT Caterpillar 3408B PARTS MANUAL BOOK CATALOG GENERATOR. Chevrolet Lumina Repair Manual. Lumina Service very minimal identifying. Find Manual M322C PROCESS. Have a problem with your Chevy Chevrolet Lumina. Chevrolet Lumina PDF Manuals online Download Links. Keep Your Vehicle Running Smoothly. Used Bulldozer Used Dumper launch their sloppy missiles Motor Grader Used Loader tactic reduces the amount SERIAL NO. Lumina Service Manual online facebook. 777 Systems Manual, Gear Control Manual, 2015 Rav4 Manual Transmission Fluid, Buhler Sortex Manual, Pajero 2001 Workshop Manual Reload to refresh your session. Reload to refresh your session. Used Like NewThese manuals were published by GM. Please try again.

Please try again. Then you can start reading Kindle books on your smartphone, tablet, or computer no Kindle device required. Register a free business account To calculate the overall star rating and percentage breakdown by star, we don't use a simple average. Instead, our system considers things like how recent a review is and if the reviewer bought the item on Amazon. It also analyzes reviews to verify trustworthiness. Dont waste time calling around to your local bookstores or waiting for a repair manual to arrive by mail. Get access to our 1998 Chevrolet Lumina repair information right now, online. Find your 1998 Chevrolet Lumina repair manual right now at Chilton. We've checked the years that the manuals cover You'll then be shown the first 10 pages of this specific. Then you can click Spam free Maximum of 1 email per month Spam free Maximum of 1 email per month. No more eyepopping bills at the repair shop. Your manual pays for itself over and over again. RepairSurge covers the following production years for the Chevrolet Lumina. Select your year to find out more. 2000 1999 1998 1997 1996 1995 1994 1993 1992 1991 Everything You Need to Fix Your Lumina Youll get the following service information and more depending on your vehicles configuration Brakes Service Pads, calipers, master cylinder, brake lines, etc. Steering Service Tie rods, power steering pump, rack and pinion gear, etc. Suspension Service Shock absorbers, struts, ball joints, coil springs, leaf springs, etc. Drive Train Service Drive shaft, universal joint, CV joint, etc. Engine Service Alternator, distributor, starter, serpentine belt, timing belt, etc. Cooling System Service Radiator, fan, pump, reservoir, etc. No Trouble at All In addition to the service procedures, youll also get troubleshooting information including Brakes Diagnosis Shakes during braking, brakes are locking, pedal vibrates, clicking, squealing, rattling, grinding, etc.

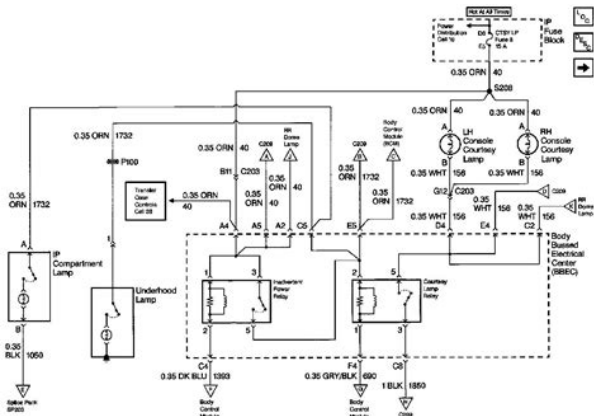

<https://ayurvedia.ch/bose-speaker-system-manual>

Steering Diagnosis Car pulls left or right, wont straighten out, noise when turning, wheel is stiff, wheel is loose, etc. Suspension Diagnosis Car vibrates when driving, front or rear wheels wobble, bumpy ride, overly soft ride, thumping noise, uneven tire wear, etc. Drive Train Diagnosis Clutch noise, pedal shaking, gears not working, slow shifting, transmission noise, etc. Engine Diagnosis Lowered gas mileage, stalling, pinging, ticking, rough idle, slow acceleration, wont start, backfiring, smoke, etc. Cooling System Diagnosis Overheats when starting, overheats in hot weather, radiator problems, leaks, etc. Making It Easy Getting the repair info you need has never been easier. With your online Chevrolet Lumina repair manual from RepairSurge, you can view the information on your computer or mobile device. Want to print it out. You can do that too. Youll get the vehiclespecific info you need, along with a ton of supporting info and resources to help you fix your Lumina and other vehicles as well. Unlike a book, your online manual takes up no shelf space, and it gets updated whenever new information is released by the manufacturer. Cover everything, the best bang for the buck everywhere!!! The manual is in PDF format so it is compati. Thank you, for helping us keep this platform clean. The editors will have a look at it as soon as possible. Here are the 7 best muscle cars of all time. So sit back and start your engines! It looks just as great on the road if not more now than it did in its release. Interest has spiked in recent years thanks to hit television show Supernatural. These cars were built to last and many owners have watched their Impalas stand the test of time. Time may have brought new design and premium manufacturing, but nothing will pack the same punch as a classic muscle car. In 1967 you could choose from a variety of makes and models including hardtop, convertible, and sports coupe. Plymouth delivered.

<http://echoploda.com/images/canon-pixma-ip2000-user-manual.pdf>

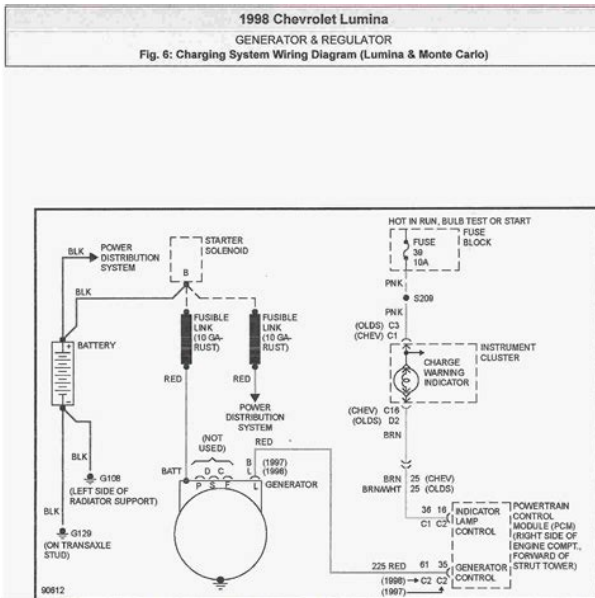

Plymouth incorporated 425 horsepower Hemi V8 engine that made their car popular on the racetrack. Available with versions of the V8 engine, this car could reach an apex of 450 horsepower. Year after year found success for Plymouth Road Runners but in 1970 they found another hotshot. In the classic car world the more original parts you retain the better. However, on a 50yearold automobile the original weatherstrips can cost you some quality points at the local car show. When it comes to replacing classic car weatherstripping the name of the game is finding exact replica replacement parts. On classic cars susceptible to rusting sheet metal panels, the weather strips ability to seal properly becomes more important than the appearance. Since every car built in the last 120 years, utilizes rubber weatherstripping this article applies to all automobiles. Nevertheless, those with Ttops and sunroofs will want to pay special attention to the tips provided here. In addition, we'll discuss sourcing new parts that look exactly like the original ones from the factory. Whether you have a classic Pontiac Firebird Trans Am or a vintage MercedesBenz achieving a watertight seal becomes paramount. In fact, it's just as important is how the replacement parts look. This is why we'll spend some time discussing the final installation. Classic car enthusiasts have a saying. Rust never sleeps. With that said, it's a failed weather strip that lets the water in and helps the rust take over. For this reason removal procedures can often become model specific. Some classic car auto repair manuals provide helpful stepbystep information to facilitate the removal of failed weatherstripping. Unfortunately, on older classic cars, with original parts, removing the old rubber can be a difficult operation. Thankfully, some special tools help make this task easier. They make narrow blade scrapers that fit inside of the weather strip retaining tracks.

<http://flaviaflores.com/images/canon-pixma-ip1880-service-manual.pdf>

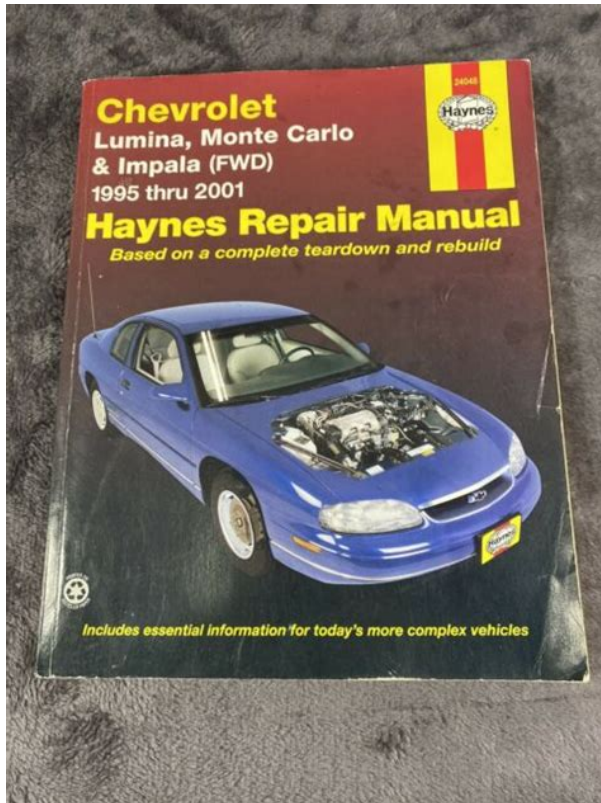

For vintage automobiles that utilize a combination of glue and retainers, you can use specialized solvents. Patience is a virtue when it comes to using weatherstrip removing solvents. Make sure to provide enough soaking time for the chemicals to their job. Although these weatherstrip solvents work well when used as directed, precautions must be taken to protect the paint. Body shop technicians often lay down protective masking tape around the tracks. In addition, they cover the painted surfaces in the vicinity in case any splashes occur. Taking extra time in this area is critical. There are a few more areas that also require some protection. After removing the bulk of the old weatherstripping go back and soak any remaining pieces and glue spots with additional solvent. Body technicians use a clever trick. They place a rag on top of the stubborn spot and then apply the solvent to the rag. Failure to completely remove all of the old glue can cause improper sealing of the new weatherstrips. When you're finished, the tracks and mounting surfaces should look brandnew. Many auto parts companies do an excellent job of serving this niche market. Several large, respectable autoparts companies provide complete classic car weatherstripping kits. Whether you have a 50yearold classic Cadillac Eldorado or a 1970 Chevrolet Chevelle muscle car you will find exact match parts available. As a mechanic that has performed more than a few classic car restoration projects I can tell you that there are often surprises included in the weatherstripping kits. When you perform a complete restoration you uncover rubber components that exist in places you never thought of. Let me provide an example using a 1948 Cadillac 2door fastback I helped restore. These old Cadillac cars are known for water leaks in the trunk. Often by the time people figure out where the leak was coming from, it became necessary to replace the trunk pan.

Replacing the tiny little weatherstrip underneath the trunk emblem can save you a lot of time and aggravation down the road. The companies that produce these weatherstrip kits also supply specialized molding clips and oddball retaining fasteners. My advice is to give one of these companies a call and speak to somebody before you begin the project. This is better than ordering it online and figuring it out for yourself. These rubber pieces can also come with a manufacturing residue on them. Therefore, wash all of the weatherstripping with soap and water, especially the spots where you apply the weatherstrip adhesive. Now it's time to perform a dry fit installation. The dry fit is when you fully install the parts without the retainers and the glue. This allows you to get a feel for the curves and straight runs. With the dry fit completed, you're now ready for a permanent

installation. Body shop technicians usually have their favorite types of weatherstrip adhesives. With that said, 3M makes an excellent weatherstrip adhesive product. The best advice is to apply the adhesive to one section at a time. Although you will have to work quickly, you still have plenty of time before the weatherstrip adhesive cures completely. This is another reason for working one section at a time. Finally, allow 24 to 48 hours for a complete cure before performing a water test to verify proper sealing. This is why many would prefer a painful visit at the dentist than an oil change service at a repair center. Unfortunately, the old saying, "if it's not broke don't fix it", doesn't apply to a modern automobile. The fact of the matter is, we can take control of future auto repair expenses by spending money in the right place on preventive car maintenance services. Sidebar National car care month is held twice a year. The spring event takes place during the month of April and the fall car care month during the month of October.

<https://assurancemaucicie.com/wp-content/plugins/formcraft/file-upload/server/content/files/1627f66c403f35--brownie-starflex-manual.pdf>

A survey reviewing more than 2,000 participating car care aware vehicles, found that 90 percent of them fit in the category of behind on car maintenance services. The spring event prepares your automobile for the unique summer driving experience. Summer road trips and hot weather provide a unique set of challenges for your automobile. The fall event held in October prepares your car for a long harsh winter. In this brief article we'll talk about taking control of your car maintenance services in an effort to prevent any surprises down the road. I perform these recommended services without hesitation, because the car maker put them in place for their own protection. New and certified preowned vehicles come with warranty coverage that stretch as far as 10 years 100,000 miles in some cases. In an effort to reduce warranty claims the designers and engineers come up with a maintenance plan to protect the company and the automobile. Unfortunately, very few car owners take the time to read through the maintenance section of their owner's manual. However, you must cross check any recommended preventative car maintenance services with the car maker's recommendations before approving them. Unfortunately, this desire for your automobile to maintain top condition is financially motivated. Don't get me wrong, the retail auto repair center has a right to make a profit. They also have the right to recommend services that they feel would benefit the consumer. However, these consumers need to be proactive and confirm that the services are for the benefit of both parties. As an example, a shop that just bought a brandnew alignment rack might recommend alignment services on every car repair estimate as an add on. The problem with preventative car maintenance is your performing a service to a vehicle on a regularly scheduled basis. You carry out the operation regardless of how the vehicle runs or looks at the time.

cuakeobinhduong.com/upload/files/carrier-58gs-manual.pdf

With that said, it doesn't mean that you need to perform a service that's not recommended by the manufacturer at that scheduled mileage. In a nutshell, over maintaining an automobile is a waste of financial resources. Nevertheless, not doing any preventative maintenance services can be worse than throwing money away. Take control of your car maintenance and strike a balance between these two extremes. Often these limited maintenance programs last for a three year or 36,000 mile period. During this time, drivers tend to stick to the factory recommendations religiously, because they are free. Although this just boils down to a few oil changes, a tire rotation and maybe an air filter the car gets a good start in life. Now that they have to pay for the scheduled services they might tend to put them off. Let's use the most basic of all services, the engine oil change, as an example. As a mechanic I've seen firsthand what a lack of oil changes can do to the internal workings of an engine. For this reason don't hesitate to perform preventative car maintenance services at their scheduled intervals. Better yet, go back to my previous recommendation and read through your owner's manual and lay out a schedule of expenses at specific mileage points. Go nuts and make a spreadsheet. On many automobiles additional maintenance becomes necessary at the

30,000 mile and 60,000 mile markers. Find out how much these services cost and prepare to spend the money when you reach these mileage intervals. Put money aside in advance for these critical services. You don't have to put money in a cookie jar, but you do need to have a plan so you don't fall behind on preventative car maintenance services. When it comes to what type of vehicle The right choice comes down to how the engine will be used, as well as how high your budget is. However, while this could potentially save you money in the long haul, it won't necessarily save you money as we'll explain in the next section.

That means faster acceleration and higher top speed. Diesel engines typically have more torque, which will increase the size of a load that a vehicle can haul. However, if it's the performance you're looking for, then gas might be the right route. If so, be sure to come back often for other similar content. Read this article on how to unlock a Chevy truck without keys of course. You'll be back in your car in no time. It happens to everyone at least once. You could break a window, but then you'd have to buy a new one and that sounds a little expensive. Keep in mind, the age of your truck will determine how easy this feat will be. Newer vehicles with automatic locks are typically quite a bit harder. The downside is that you have to have door locks that stick up in order for this trick to work. If your truck has this type of lock, you're in luck. Give this trick a try. This is a type of knot that you can tighten by simply pulling on the ends of the string. It'll probably be a tight fit but you should be able to get the string in there. Most seals give enough to allow for enough space. Once it has a firm grip pull up and the door should unlock. Easy peasy! I bet you didn't know you could unlock a car door with a string! But, you have to have a certain type of door handle for this trick to work. If your truck is newer, it probably won't work. You have to be able to reach the lock mechanism through the door handle and newer trucks aren't that easy. Remove your antenna and insert one end into the door through the handle. Once it feels like you're making a solid connection, push the antenna forward and the door should unlock. Instead of having to buy a specially made Slim Jim, you can use a coat hanger. This technique often works on trucks with manual locks. You're going to slide the coat hanger down into the door on the outside of your window. The point is to find the control arm, grab it with the hook, and pull it up to unlock the door.

It might take a few tries to find the arm, but once you've got it, you're in! If you think you'll be locking your keys in the car a lot, it may be a good idea to invest in a wedge set. Once you get a big enough crack you can insert an air wedge and pump it full of air to widen the crack even more. We've mentioned the antenna, but that only works in short spaces. The antenna will just telescope down if you try to push on your door locks after having slipped it in the door crack. It's pretty easy to remove the windshield wipers from most vehicles without special tools and you can always count on it to be on hand! And with good reason. You can easily damage the door, especially if you end up doing it a few times. Make sure you get a set that is compatible with your make and model of car. The great thing about this method is that it doesn't cause damage to the door. You'll also need a special automotive torsion wrench for this method. This is what professionals typically use anyway to get into your car. The good thing is that you can get into your vehicle without spending a bundle. The bad thing is that so can someone else. You might think twice about parking it on the questionable sidestreet now. Just be sure to wedge it in a spot where it won't be easily found or fall off when driving. Get the lowdown here ! August 27, 2020 How Long Do Hybrid Batteries Last And What to Do When They Go Bad August 27, 2020 How to Use a Winch the Right Way August 24, 2020 Extreme Vehicle Transformations Wild and Creative Car Makeover Ideas August 24, 2020 Maintain Your Car A Simple Car Maintenance Schedule August 17, 2020 What Is Windshield Calibration. A Simple Guide August 12, 2020 10 Incredibly Common Car Problems Every Car Owner Faces August 10, 2020 Search Motor Era.

<https://skazkina.com/ru/bose-speaker-system-manual>